

Wunder-Bar™

AUTO-SAUCE®

PIZZA SAUCE DISPENSER



For Systems with the model numbers
RSD-1-RTU-(1)-CWSS-(2)

Rotary **S**auce **D**ispenser
1 = 1 Sauce

RTU = Ready-To-Use sauce

(1) = Pizza Types/Sizes (1 to 15)

CW = ClockWise turntable rotation

SS = Stainless Steel Top, Rotomold Bottom
(2) = Customer Code

100-240 VAC, 50/60Hz, 1 Phase
110VAC, 2.5A / 220VAC, 1.5A



Manufactured under one or more Patents and
Applications: US Patent Nos.: 6,892,901;
6,892,629; 6,969,015; 7,074,277; 7,993,049

Canadian Patents: CA2740766_C, CA2912970

SERVICE AND FACTORY ASSISTANCE:

Please record your Installer/Service Agent's name and phone number here for future reference:

SERIAL NUMBER: _____ DATE OF INSTALLATION: _____

SERVICE AGENT NAME: _____ PHONE: _____ PAGER: _____

Service Assistance: call Wunder-Bar "Toll Free Service Hotline" @ 866-986-3372 anytime,
or (707) 448-5151 Monday through Friday, 7:00 AM to 5:00 PM Pacific Time.

Wunder-Bar™

ATTENTION!

- Read all Instructions before setting up or operating the dispenser.
- Always disconnect the main power cord from the electrical source before removing any access panels or attempting to perform any servicing of this dispenser.
- Do not operate the dispenser with a damaged power cord or if the equipment has been dropped or damaged—until it has been examined by a qualified service person.
- The dispenser should never be cleaned using a water jet.
- Service access panels should be removed by qualified service technicians, **ONLY**.
- Access to the service areas of this dispenser is restricted to qualified technicians with safety/hygiene knowledge, experience, and training for servicing this specific dispenser.
- Install and use this dispenser only as described in this instruction manual. Use only the manufacturer's recommended attachments.
- **This dispenser should be operated in the ambient temperatures: MIN: 2° C, 36° F MAX: 40° C, 104° F**
- **The maximum measured "A" weighted sound measurement for this Auto Saucer is 72.1dBA.**
- **The maximum measured "C" weighted sound measurement for this Auto Saucer is 82.2dBC.**

- Lire toutes les instructions avant d'installer ou d'utiliser le distributeur.
- Toujours débrancher le cordon d'alimentation de la source électrique avant de retirer les panneaux d'accès ou de tenter d'effectuer toute intervention de ce distributeur.
- Ne pas faire fonctionner le distributeur avec un cordon d'alimentation endommagé ou si l'équipement a été échappé ou endommagé, jusqu'à ce qu'il ait été examiné par un technicien qualifié.
- Le distributeur ne doit jamais être nettoyé avec un jet d'eau.
- Panneaux d'accès aux services doivent être enlevés par des techniciens qualifiés, **SEULEMENT**.
- Accès aux zones de service de ce distributeur est limitée à des techniciens qualifiés de la sécurité / des connaissances d'hygiène, l'expérience et la formation pour l'entretien de ce distributeur spécifique.
- Installer et utiliser ce distributeur tel que décrit dans ce manuel d'instruction. Utilisez uniquement du fabricant les accessoires recommandés par.
- **Ce distributeur ne doit être utilisé dans les températures ambiantes: MIN: 2° C, 36° F MAX: 40° C, 104° F**
- **La mesure du son pondérée "A" mesurée maximum pour cette auto-soucoupe est 72.1dBA.**
- **La mesure de son pondérée maximale "C" mesurée pour cette soucoupe automatique est de 82.2dBC.**

This equipment is rated for indoor use only. It will not operate in sub-freezing temperature. In a situation when temperatures drop below freezing, the equipment must be turned off immediately and properly winterized.

Removal from Service

GENERAL

Special precautions must be taken if the dispenser is to be removed from service for an extended period of time or exposed to ambient temperatures of 32°F (0°C) or below.

CAUTION

If water or sauce is allowed to remain in the dispenser in freezing temperatures, severe damage to some components could result. Damage of this nature is not covered by the warranty.

Cet équipement est conçu pour une utilisation en intérieur. Il ne sera pas fonctionner en sous-température de congélation. Dans une situation où les températures descendent en dessous de zéro, l'équipement doit être éteint immédiatement et correctement pour l'hiver.

Retrait du service / Hivérization

GENERAL

Des précautions particulières doivent être prises si le distributeur doit être retiré du service pour une période de temps prolongée ou exposé à des températures ambiantes de 32 ° F (0 ° C) ou au-dessous.

ATTENTION

Si l'eau est autorisé à rester dans le distributeur en températures de congélation, de graves dommages dans une certaine composants pourraient en résulter. Les dommages de cette nature est ne sont pas couverts par la garantie.

PROCÉDURE HIVÉRISATION

1. Fermez le robinet et retirez bac d'approvisionnement sauce.
2. Débrancher la conduite d'eau entrant à l'arrière du distributeur sauce.
3. Ouvrez le robinet bleu / blanc de l'eau d'essai situé sur la pompe.
4. Souffler de l'air comprimé par l'orifice jusqu'à ce que l'eau existe pas la vanne d'essai.
5. Assurez-vous que l'eau n'est pas pris au piège dans l'une des lignes d'approvisionnement en eau.
6. Débranchez le cordon d'alimentation électrique de la prise murale.

Wunder-Bar™

TABLE OF CONTENTS

SAFETY	2
TABLE OF CONTENTS	3
INTRODUCTION	4
SPECIFICATION	
PARTS ID	5
KEYPAD OVERVIEW	6
SPECIFICATION SHEET	7
OPERATIONS	
FILLING SAUCE VAT & PRIMING DISPENSER	8
OPERATING PROCEDURES	9
CLEANING PROCEDURES	
CLEANING SOLUTION PREPARATION	10
PUMP INLET STRAINER CLEANING INSTRUCTIONS	11
VAT CLEANING INSTRUCTIONS	12
NOZZLE CLEANING INSTRUCTIONS	13
AUTO-Saucer CLEANING PROCEDURES	14
(OPTIONAL) TOTAL SAUCE CAPTURE	16
DAILY MAINTENANCE	17
SPARE PARTS LIST	18

Wunder-Bar™

INTRODUCTION

What It Is

The Auto-Saucer® Dispenser from Wunder-Bar® is a low cost, fast and accurate pizza sauce dispenser and spreader. The linear arm dispenses an even and consistent amount of sauce across the dough each and every time.

It significantly improves PRODUCT QUALITY and CONSISTENCY while improving PRODUCTIVITY and MARGINS!

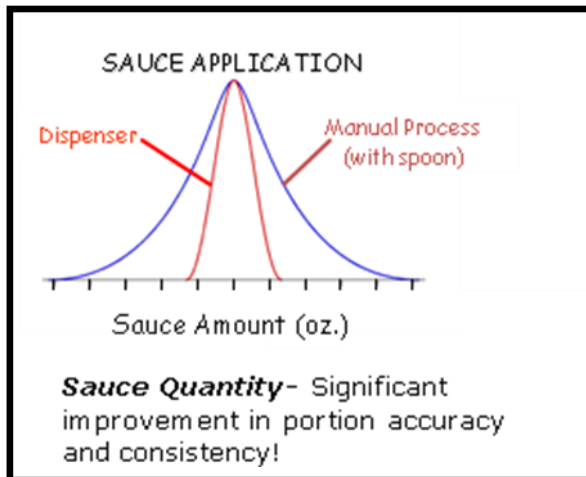

When the pizza dough is placed onto the turntable and the dispense button is pressed, the sauce concentrate is pulled into the pump chamber. It then travels up and into the sauce dispensing arm. The arm moves across the spinning pizza and dispenses the sauce in spiral pattern. Perfectly sauced pizzas at the touch of a button!

Clean-up is simple with an automated Clean-In-Place routine. It practically cleans itself in less than 10 minutes.

IMPORTANT: the top and bottom assemblies contain computer boards and other electrical connections that will fail if contacted with water. Do not spray the Auto-Saucer® Dispenser with water! Use moist cleaning cloth to wipe down outside of dispenser.

CAUTION—Risk of fire and electric shock. Use only with the original equipment manufacturer's power cord set.

Wunder-Bar™

SPECIFICATIONS

AUTO-SAUCCER DISPENSER PARTS IDENTIFICATION

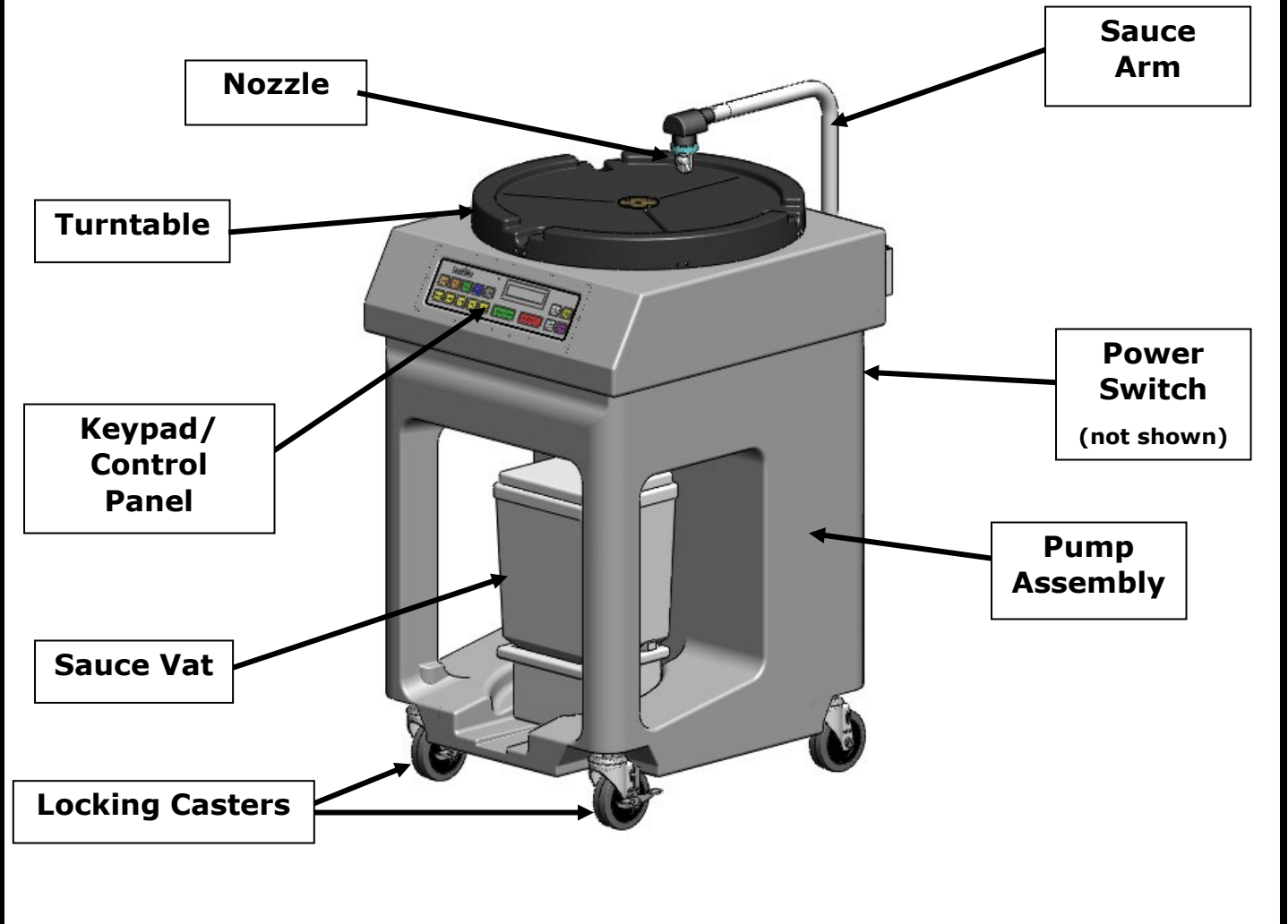

Machine Features

- **Sauce Vat-** Holds sauce concentrate before the auto saucer mixes it with water and dispenses it on a pizza - *May be square (RTM) as shown, or circular (RTU) with a Dip Tube*
- **Pump Assembly-** Where the Auto-Saucer pumps sauce through the dispenser
- **Turntable** Spins the pizza during saucing for even distribution
- **Sauce Arm-** moves across pizza to dispense sauce
- **Nozzle Assembly-** Distributes the sauce from the hose onto a pizza
- **Keypad with LCD-** Operates the auto saucer

Wunder-Bar™

SPECIFICATIONS

KEYPAD OVERVIEW



KEYPAD FEATURES

- **Dispense / Enter-** Used to sauce a pizza
- **LCD Window-** Displays information to the user
- **Prime/Total Cap.-** Prepares the auto saucer to dispense by filling the pump with sauce. Used to at the beginning of the day and when fresh vats are placed onto the dispenser, or for the total sauce capture feature
- **Sanitize-** Initiates the automated clean-in-place cleaning routine. Used at the end of each day.
- **Cancel-** Clear the current function or STOPS a dispense cycle
- **+ or – Buttons or More/Less Sauce-** Settings for Extra or Light Sauce
- **Numeric Buttons–** Where Pizza Settings are, if applicable
 - Top Row = Pizza Sizes, if applicable
 - Bottom Row = Dough Type, if applicable
 - Use the LED's to guide your selection
 - **If you only have one size AND one type**, there will be no settings on the numeric buttons
 - Press Dispense / Enter to sauce
 - **If you only have one type and multiple sizes**, there will only be settings on the top row
 - Press what size you want then press Dispense / Enter to sauce
 - **If you have multiple sizes and types**, there will be settings on both rows
 - Press one selection from the top row, then one selection from the bottom row and press Dispense / Enter to sauce

UNPACKING

The saucer is shipped fully assembled and operationally pre-tested, in a large card board box. Remove all wrapping material, supports, and packing material from the Auto-Saucer® before setting up and attempting to start-up the Auto-Saucer®.

Wunder-Bar™

SPECIFICATIONS

MODEL: RSD-1-RTU-(1)-CW-SS

READY-TO-USE ROTARY SAUCE DISPENSER - COUNTERTOP
CLOCKWISE ROTATION
(1) = 1 TO 15 PIZZA SIZES/TYPES

DOC NO:
RSD-RTUM24031

REV:
A



DATE:
Feb 16, 2024

PRODUCT SPECIFICATIONS:

DISPENSER: LINEAR ARM FOR SAUCE DISPENSING, ONE PRODUCT, PROGRAMMABLE POUR SIZES AND DISPENSE DIAMETERS, UP TO 15 PRESET PIZZA SIZES/TYPES

CONSTRUCTION: TOP ENCLOSURE: STAINLESS STEEL
BOTTOM ENCLOSURE: SEAMLESS DARK GRAY UL RATED POLYETHYLENE
TURNTABLES: ABS OR POLYETHYLENE

VAT CAPACITY: 22 QUARTS, 5-1/2 GALLONS OF READY-TO-USE PIZZA SAUCE

MANUFACTURED UNDER ONE OR MORE PATENTS AND APPLICATIONS:
6,892,901; 6,892,629; 6,989,015; 7,074,277



INSTALLATION REQUIREMENTS:

ELECTRICAL: 100-240 VAC, 50/60 Hz, 1 Phase
110VAC, 2.5A / 220VAC, 1.5A
- GROUNDED OUTLET REQUIRED WITHIN 3 FEET OF SAUCER.

- PIZZA SAUCE DISPENSERS WILL FULLY FUNCTION AT ALTITUDES UP TO 1000m ABOVE SEA LEVEL
- PIZZA SAUCE DISPENSER TRANSPORTATION AND STORAGE TEMPERATURE RANGE IS AT LEAST -25°C TO +55°C

DISPENSER FEATURES:

- DISPENSES SHELF-STABLE READY-TO-USE PIZZA SAUCE
- CLOCKWISE ROTATION
- CUP FEATURE FOR PROGRAMMABLE DIPPING SAUCE DISPENSER
- LESS & MORE BUTTONS. DECREASE OR INCREASE PORTION BY PROGRAMMED AMOUNT
- UL RATED POLYETHYLENE ENCLOSURE AND BASE, ABS OR POLYETHYLENE TURNTABLE
- ONE (1) 22 QUART, 5-1/2 GALLON NSF VAT WITH LID INCLUDED. ADDITIONAL VATS AVAILABLE AT EXTRA COST
- AUTOMATIC SANITIZING ROUTINE. 1 NOZZLE SANITIZER ADAPTER WITH 5' HOSE INCLUDED
- FULLY FACTORY ASSEMBLED AND WET-CHECKED

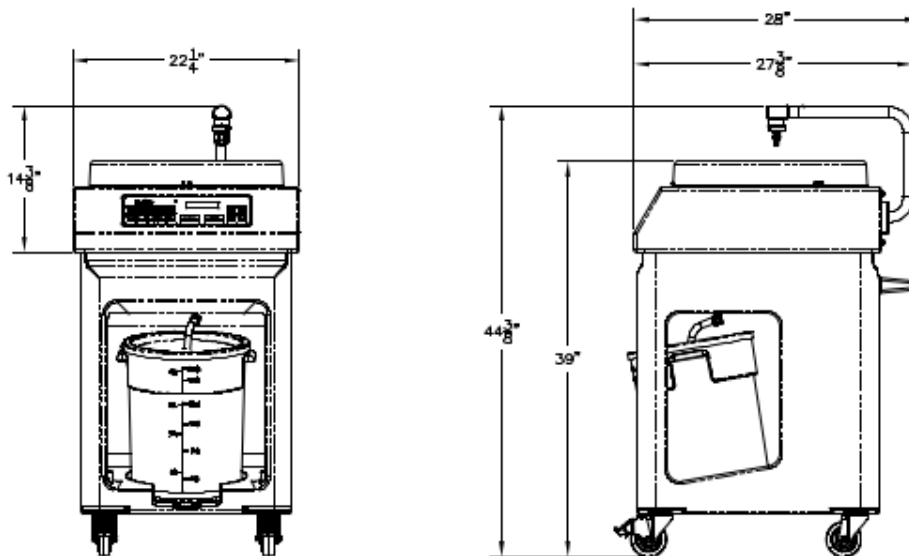
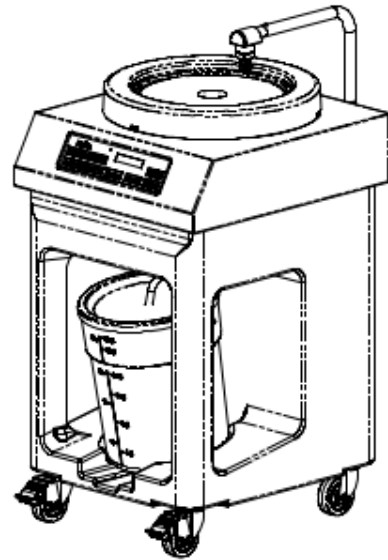

Wunder-Bar™

AUTOMATIC BAR CONTROLS, INC.
2060 CESSNA DR, SUITE 100
VACAVILLE, CA 95688

WWW.WUNDERBAR.COM

TOLL FREE : (800) 722-6738
PHONE : (707) 448-5151
FAX : (707) 448-1521

Wunder-Bar™



FILLING SAUCE VAT & PRIMING DISPENSER

NEVER ADD SAUCE TO A VAT THAT HAS NOT BEEN CLEANED FIRST

READY-TO-USE PIZZA SAUCE HANDLING PROCEDURES

1. Fill the Vat(s) with enough Ready-to-Use Sauce for 3 to 4 hours of business, maximum.
2. Each sauce Vat will hold up to 22 quarts (5-1/2 gallons) of Ready-to-Use Pizza Sauce.
3. Install the included spare cover(s) on all vats to be filled and refrigerated. Be careful not to touch the inside of the vat or cover with bare hands or arms.
4. All back-up sauce-filled Vats must be kept refrigerated at 38° F until it is to be used on the dispenser.
5. When the sauce Vat is empty, remove it from auto saucer and replace with a new Vat. **Never add new sauce to old sauce.**
6. The soiled Vat and Cover must be washed, rinsed, sanitized and allowed to air dry before refilling with new Sauce. (See *Vat Cleaning Instructions* section of this manual)



1st: Place bag on clean flat surface. Remove sauce from corner where the "easy Tear" is located. Use perforated edge to tear the bag open.



2nd: **Use a Clean Vat**
Fill the Vat with up to 20 quarts or 5 gallons of RTU sauce. **Squeeze all sauce out of bag!**



3rd: Place the sauce-filled Vat down into the recess in the slanted Rack base. Install the cover onto the Vat and snap the rim in place.



4th: Insert the Dip Tube thru the hole in the cover so that the Dip Tube end is oriented toward the front or lowest side of the Vat.



5th: Confirm that the Main Power Switch is ON. The Main Power Switch is located on the upper right side of the back splash.



6th: Position a catch pan under the Nozzle Mount.



7th: **Double-press** "Prime" button to begin the automatic priming cycle (It may say "Prime/Total Cap.")

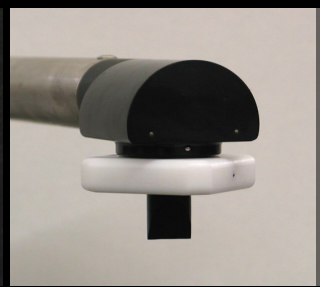

8th: **OPTIONAL**
If system does not prime, install the Priming Nozzle onto the Nozzle Mount. Re-try



9th: **(Remove Priming Nozzle if used)** Install Nozzle : Grasp and turn the nozzle Clockwise until the silver dots are aligned.



10th: The pump will fill and dispense 4 times and then stop. (Display will say: PRIMING Pushing Sauce Out #1, PRIMING Pushing Sauce Out #2, then #3, and then #4.



11th: Wait until the display is home.
Then remove Catch Pan and discard product.

Wunder-Bar™



OPERATING INSTRUCTIONS



1st: Install The Nozzle
Push the Nozzle onto the Nozzle Mount with the dots aligned.

2nd: Lock the Nozzle
Turn the Nozzle (right) counter- clockwise to lock nozzle in place.

3rd: Power Up the System
Turn Main Power Switch ON. (located on rear side of lower cabinet)

4th: Display be home and say: "Make Pizza"/"Food Court" or similar

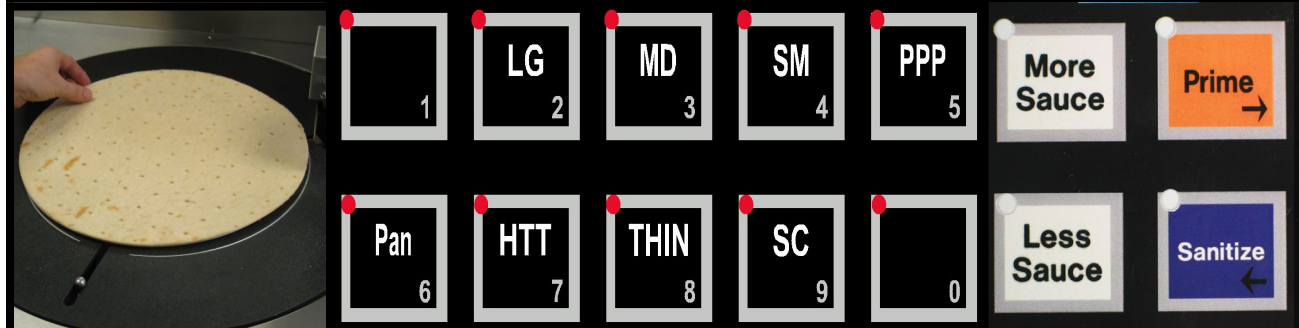

5th: Place the dough onto the pan with the dough edge even with rim. Place the dough close to the center of the turntable. Use the locator rings to align pan.

6th: Select Size
Select and press the pizza size button from the top row of buttons, if applicable. **If you don't have options here, you can skip this step**

7th: Select Dough Type
Select and press dough type button from the bottom row of buttons. **If you don't have options here, you can skip this step**

8th: OPTIONAL
Each Button Press of "More" or "Less" increases or decreases the amount of sauce. Otherwise, **you can skip this step**

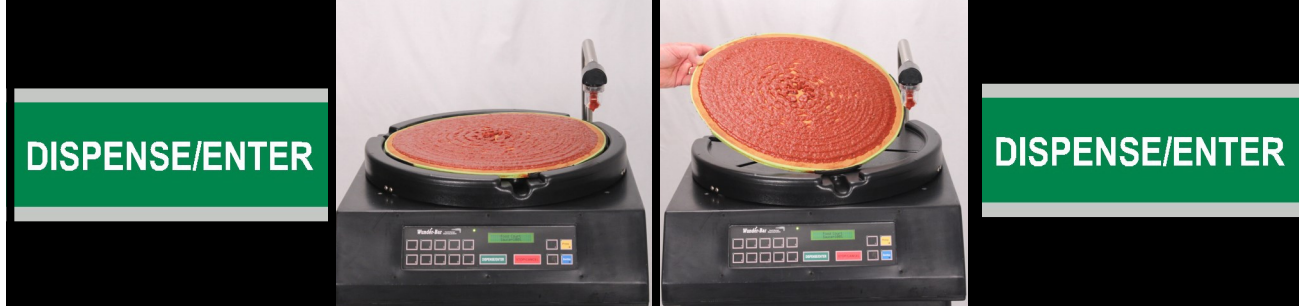

9th: Press "DISPENSE/ENTER" to dispense sauce.

10th: Sauce is Dispensed
The pan rotates and the sauce is evenly dispensed.

11th: Remove Sauced Dough
Remove the sauced dough only when the pan has completely stopped turning.

12th: REPEAT DISPENSE
The same size/type pizza may be poured a multiple number of times by pressing DISPENSE/ENTER button

Wunder-Bar™



CLEANING SOLUTION PREPARATION

STERA-SHEEN GREEN LABEL SOLUTION INSTRUCTIONS

Prepare a kitchen wash sink, vat or other container with Stera-Sheen Green Label.

1. Fill the sink or container with an appropriate amount of lukewarm water based on capacity. Dissolve Stera-Sheen Green label in water maintaining the mixing ratio of 2oz. Of Stera-Sheen Green Label to 2gal. of water; 4oz. to 4gal.; or 6oz to 6gal.



*Stera-Sheen Green Label comes in either a 2oz. packet or a jar and **acts as both a detergent and sanitizer**

1gal = 4qts	2gal = 8qts
3gal = 12qts	4gal = 16qts

Note: Proper mixing ratios will achieve a 100ppm solution. Use Chlorine Test Strips to confirm 100ppm solution by dipping a test strip into the Stera Sheen Solution and comparing the strip with the chart on the package.

Safety Data Sheet:
<http://q-r.to/glsds>

CHLORSAN NP SOLUTION INSTRUCTIONS

Prepare a kitchen wash sink, vat or other container with Chlorsan NP Solution.

1. Fill the sink or container with an appropriate amount of lukewarm water based on capacity. Dissolve Chlorsan NP in the water maintaining the mixing ratio of one packet (1oz.) of Chlorsan NP to 2.5gal. of water; 2 packets (2oz.) to 5gal.; or 3 packets (3oz.) to 7.5gal. of water



*Chlorsan NP comes in 1oz. Packets and **acts as both a detergent and sanitizer**

1gal = 4qts	2gal = 8qts
3gal = 12qts	4gal = 16qts

Note: Proper mixing ratios will achieve a 100ppm solution. Use Chlorine Test Strips to confirm 100ppm solution by dipping a test strip into the Chlorsan NP solution and comparing the strip with the chart on the package.

Safety Data Sheet:
<US-Z8-924736-04-CHLORSAN NP.pdf>

GENERIC SOLUTION INSTRUCTIONS

Generic Cleaning Solutions utilize both a Low Foaming Non-caustic detergent/dish soap and a Quaternary Sanitizer capable of producing 200ppm solutions in the cleaning process.

During the multi-step cleaning processes:

1. The detergent will be used first
2. The sanitizer will be used second

1gal = 4qts	2gal = 8qts
3gal = 12qts	4gal = 16qts

Follow manufacturer's preparation and handling instructions when mixing detergent and sanitizing solutions.

Wunder-Bar™



VAT CLEANING INSTRUCTIONS

NEVER ADD SAUCE TO A VAT THAT HAS NOT BEEN CLEANED FIRST

ALWAYS WASH, RINSE AND SANITIZE THE VAT AND COVER BEFORE REFILLING THE VAT WITH FRESH SAUCE



2nd: Slide the Vat Rack out fully. Remove Dip Tube and Cover from the Vat. If empty, proceed to Step 4. If Vat contains sauce less than 4hrs old, proceed to step 3



3rd: Cover the Vat with a clean, non-hole cover. Immediately place the vat with sauce into a refrigerator or cooler. Use this sauce first, the next day



4th: If the Vat is empty, fill the vat with HOT water, allow to soak, and then rinse out all remaining sauce residue.



5th: Wash the Vat and Cover in the left sink containing the detergent solution. See Pg 10 for detergent prep. steps



6th: Rinse the Vat and Cover in the center sink. The center sink should contain Hot tap water.



7th: Sanitize the Vat and Cover in the right sink containing the sanitizing solution. Let sit for at least 1 minute . See Pg 10 for sanitizing prep steps



8th: Place the Vat and Cover on the clean drain board to dry

Note: Separate batches of Stera Sheen Green Label and Chlorsan NP can be used for both the detergent and sanitizing steps. Please refer to Page 10 for details

Wunder-Bar™

NSF

INLET STRAINER CLEANING INSTRUCTIONS

CLEAN THE STRAINER ONCE PER WEEK OR WHEN PUMP WILL NOT PRIME

 <p>Strainer Pump Enclosure</p>	 <p>Strainer Inlet Strainer</p>	 <p>Strainer Outlet Strainer</p>	
<p>2nd: Turn the system OFF The Strainer Assembly is located at the lower left rear of the Pump Enclosure.</p>	<p>3rd: Grasp and pull the Strainer Inlet away from the Strainer. Place the Inlet on a clean surface or container.</p>	<p>4th: Grasp the Strainer pull it away from the Strainer Outlet</p> <p>Wipe down the strainer outlet with a clean, wet towel to remove any debris</p> <p>Take a second clean towel with sanitizer solution from the first container and wipe down the strainer outlet</p>	<p>5th: Rinse the Strainer under warm tap water until the majority of sauce and spices are removed.</p>
			
<p>6th: Soak the Strainer in the first container of detergent solution for five minutes. Brush clean with 1/4" bristle brush to remove sauce from all holes. Pg 10 for detergent prep. steps</p>	<p>7th: Thoroughly rinse the Strainer under warm tap water to remove any remaining sauce residue and detergent Solution</p>	<p>8th: Soak the Strainer in the container of sanitizing solution for one minute. Remove from the solution and allow to air dry. Pg 10 for sanitizing prep. steps</p>	<p>9th: Assemble the Strainer Assembly (repeating steps 3 and 4 in reverse order). Resume operation of the system.</p>







Note: Separate batches of Stera Sheen Green Label and Chlorsan NP can be used for both the detergent and sanitizing steps. Please refer to Page 10 for details

Wunder-Bar™

NSF

NOZZLE CLEANING INSTRUCTIONS

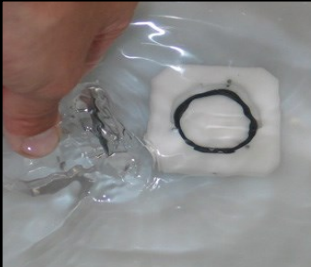
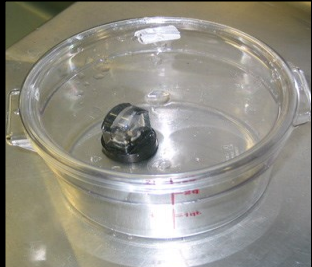
ALWAYS WASH, RINSE, AND SANITIZE NOZZLE BEFORE INSTALLING ONTO DISPENSE ARM

			
<p>2nd: Grasp and turn the nozzle Clockwise until the silver dots are aligned</p>	<p>3rd: Pull the Nozzle down and away from the mount. Wash, Rinse and Sanitize the nozzle before re-using</p>	<p>4th: Wipe down the nozzle mount with a clean, wet towel to remove any debris</p> <p>Take a second clean towel saturated with sanitizer solution from the 1st container</p> <p>Allow to air dry prior to installing a clean and sanitized nozzle</p>	<p>5th: Soak the nozzle in the 1st container of detergent solution for five minutes. Brush clean with a 1/4" bristle brush to remove any remaining sauce</p>
			
<p>6th: Soak the nozzle in the container of sanitizing solution for one minute. Remove from the solution and allow to air dry.</p>	<p>7th: If the nozzle is not to be used immediately, store the clean nozzle (and any spacer) in a covered sanitary container until next use</p>	<p>8th: Install the nozzle so that the silver dots are aligned</p>	<p>9th: Turn the nozzle counterclockwise until it stops</p>

Note: Separate batches of Stera Sheen Green Label and Chlorsan NP can be used for both the detergent and sanitizing steps. Please refer to Page 10 for details

Wunder-Bar™



AUTO-SAUCCER® CLEANING PROCEDURES

THE AUTO-SAUCCER® MUST BE CLEANED DAILY

<p>1st: <u>Remove the Vat and Dip Tube</u> Slide the Vat outward—away from the pump. Clean soiled Vat before refilling. See <i>Vat Cleaning Instructions</i></p>	<p>2nd: Prepare your detergent solution and sanitizing solution. If they are separate chemicals, you must use two separate containers. If you are using Stera Sheen Green Label or Chlorsan NP, you do not need to use separate containers. See Page 10 for preparation details and mixing ratios.</p>	<p>3rd: <u>Remove Nozzle</u> Grasp and turn the nozzle Clockwise until the silver dots are aligned.</p>	<p>4th: Pull the Nozzle down and away from the Nozzle Mount. Wash, Rinse, and Sanitize the Nozzle before reusing. See <i>Nozzle Cleaning Instructions</i></p>
<p>5th: Place a clean sauce catch pan under the nozzle to capture useable sauce remaining in the system.</p>			
<p>6th: Display should be at home *Optional*: See <i>Total Sauce Capture Instructions</i> Double-press <u>Sanitize</u> button</p>	<p>7th: Display should now say: "Ready Capture Sauce" Position a clean pan on the turntable, press DISPENSE/ENTER</p>	<p>8th: Display should say: "Manually Capture" "Use Basket" Usable sauce will be dispensed</p>	
<p>9th: Install the Nozzle Cleaning Adapter onto Nozzle Mount . Turn the Adapter CounterClockwise to lock. Place the hose-end into a waste pail or waste sink.</p>			
<p>10th: Place the Vat filled with detergent solution in front of the Sauce Dispenser. Place the Dip Tube into the Vat filled with detergent solution</p>	<p>11th: Press the <u>DISPENSE/ENTER</u> button to begin the 3 minute Wash segment.</p>	<p>12th: The Wash cycle will run for 3 minutes and the display say: "Wash Cycle..." "Total time 00:01" The Wash Cycle will automatically continue until the timer reaches 03.00 (3 minutes).</p>	

Wunder-Bar™



AUTO-SAUCCER® CLEANING PROCEDURES

THE AUTO-SAUCCER® MUST BE CLEANED DAILY



13th: When timer reaches 03:00 pump will stop and display will say: "Ready to Rinse" "Press ENTER"
If you are using a separate sanitizer, move the sanitizing hose from the detergent container to the sanitizer container

Ready to Rinse
Press ENTER

DISPENSE/ENTER

14th: "Ready to Rinse" "Press ENTER"

Press **DISPENSE/ENTER** to start the 2 minute Rinse Cycle.

Rinse Cycle...
Total Time 04:59

Dwell After Rinse...
Total Time 05:59

15th: The 2 minute Rinse cycle will continue until the timer reaches 05:00 and the pump stops. The display will now say: "Dwell After Rinse" "Total Time 05:01" (The 1 minute Dwell Cycle will end at 6:00)

Sanitizing Cycle...
Total Time 06:05

16th: **The 1 minute Sanitize Cycle will automatically start after the 1 minute Dwell Cycle.** The display will say: "Sanitizing Cycle..." Total time 06:01"

Sanitize Completed
Press CANCEL

STOP/CANCEL



18th: Move the Operation Switch to the OFF position.



19th: Pull downward on the Nozzle Adapter to remove the Adapter from the Nozzle Mount. Store the Sanitizer hose in a clean container or plastic bag.



20th: Install the CLEAN Nozzle onto the Nozzle Mount with the two silver dots aligned, as shown above. Turn the Nozzle Counter-clockwise until it stops.

17th: The Sanitizing Cycle will automatically stop when the timer reaches 7:00 and the display says: "Sanitize Completed" "Press Cancel"



21st: If the system is to be used immediately, proceed to "Filling Sauce Vat & Priming". If not, place a CLEAN Vat onto the Vat Rack. Install a CLEAN Cover. **Insert the Dip Tube into the CLEAN Vat until the system is to be used next**





THIS SPACE IS INTENTIONALLY LEFT BLANK

Wunder-Bar™

NSF

AUTO-SaucER® TOTAL SAUCE CAPTURE

TOTAL SAUCE CAPTURE: Is an optional method of reducing wasted sauce at the end of the day and is only preformed immediately before the automated cleaning process/closing procedures

			
<p>1st: Remove dip tube from the vat</p>	<p>2nd: Ensure a clean sauce catch pan under the nozzle to capture useable sauce remaining in the system is placed</p>	<p>3rd: <u>Double-press</u> Prime / Total Cap. button to begin the automatic priming cycle.</p>	<p>4th: Usable sauce will be dispensed (Display will say: PRIMING Pushing Sauce Out #1, PRIMING Pushing Sauce Out #2, then #3, and then #4.</p>



<p>6th: Display should say: "Food Court" <u>Double-press</u> Sanitize button And continue with the closing procedures on page 13, Step 7.</p>

THIS SPACE IS INTENTIONALLY LEFT BLANK

Wunder-Bar™

NSF

DAILY MAINTENANCE



Lift off turntable. Wipe the dispenser top with a DAMP cloth.



Spin all wheels. If any doesn't spin freely, have it replaced by factory tech.



Brush nozzle following instructions



Clean nozzle following instructions

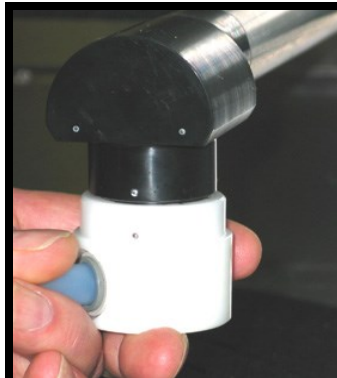

CLEAN SAUCE DISPENSER

Attach Cleaning Adapter to nozzle mount and place other end in cleaning solution
Capture sauce, then run automatic cleaning routine.



Follow the saucer's ON-SCREEN instructions for daily cleaning.

Sanitize Completed
Press CANCEL

STOP/CANCEL

When Auto Cleaning is complete press
STOP/CANCEL
Remove Adapter, install Nozzle, attach Sauce vat.

DON'T DO



Pour water or cleaner onto dispenser or wet sponge to wipe the dispenser.

